



The production capacity

Since 2006, the company is located in a building of 9600 sq.ft. in the industrial park of the city of Drummondville in Quebec, disposing of a vast workshop area. This shop is equipped with a completely automated system for cutting, marking and treating the wires used in our control panels. This same equipment is used in the manufacturing of harnesses and cables custom-made for mobile applications and stationary machines.

Two testing benches with the following available voltage: 600V, 480V, 400V, 240V, 208V and 120V to insure that each panel manufactured be tested and checked before being sent to the client.



Details that make a difference

- Systematic use of ferrules on wire ends.
- Computer-assisted conception for the realization of electrical schematics.
- Self-adhesive identification stickers to tag terminal connections for on site wiring.
- 24h, 7 days a week assistance.

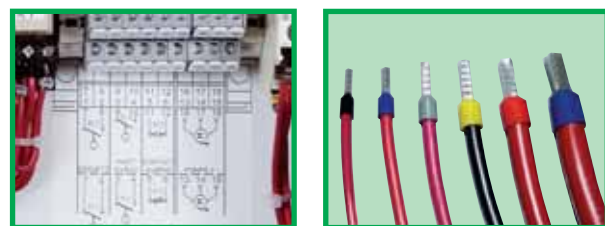

Electrical schematic

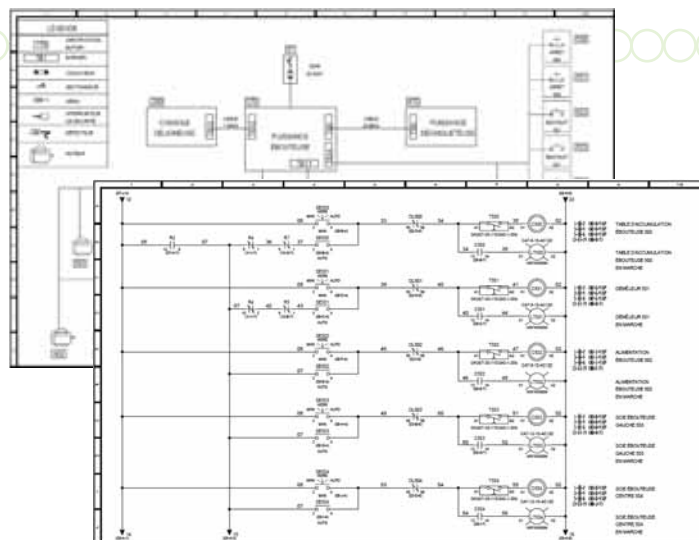

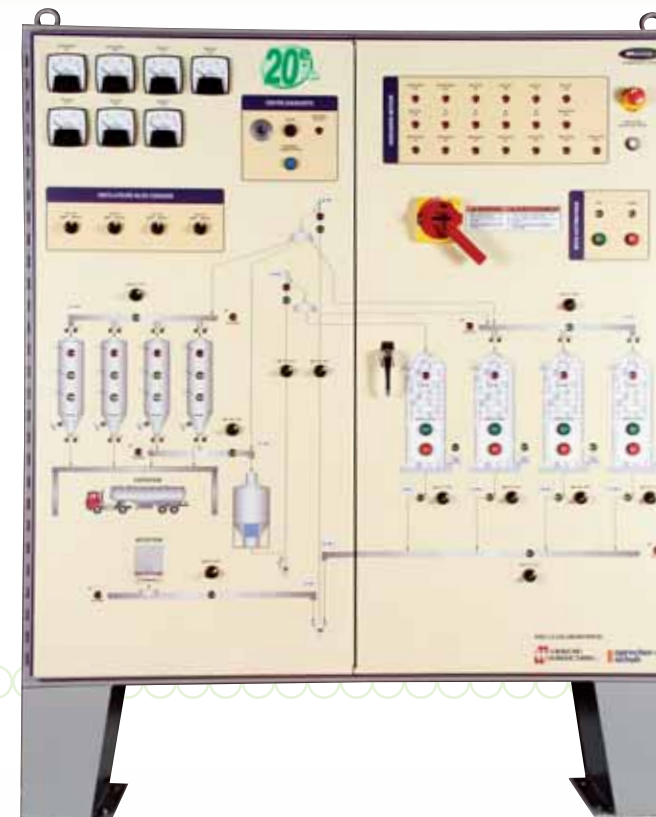

The flexibility and the controlling versatility in industrial automation



Multico is a business specializing in the design and manufacturing of control panels for various applications in the industrial and commercial sectors. The needs of our clients have greatly evolved since our company's beginnings in 1988, as have the products that we are now able to offer. The use of automation components such as programmable logic controller (PLC) in different projects illustrates very clearly this evolution.

Products approval

All of the control panels have been approved according to the standard of the CSA 22.2 14-05 and bear the marking  for Canada and  for the United States. We are also able to comply to the requirements of the European market by offering the marking  on all admissible panels.

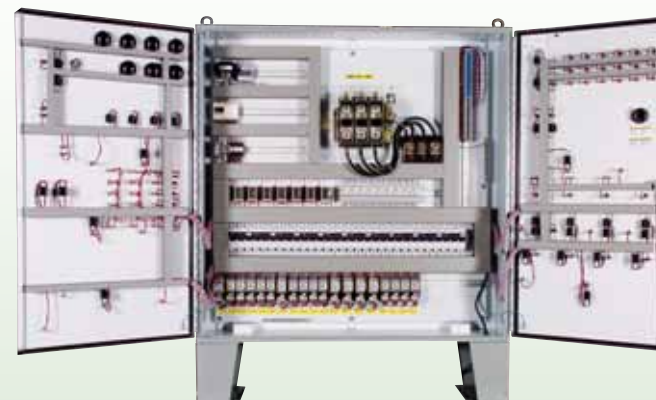

Multico Electrique inc.

1000, Bergeron street Drummondville (Quebec) Canada J2C 0C1

Phone: (819) 477-6777 • Fax: (819) 478-0198

E-mail: multico@multicoelectric.com

Multico Electrique inc. reserves the right to modify, at all times, the manufacturing and/or the characteristics and/or the design of its products without prior warning.



Certified quality

The company carries out a constant quality control at every stage of manufacturing, from design to shipping. These controls are executed while respecting and applying the certification ISO 9001- 2000 for several years now already. The active involvement of all of Multico's trained staff in the search for quality, results in a continuous improvement of the products and services we offer, thanks to the daily feedback and brainstorming between the different departments.

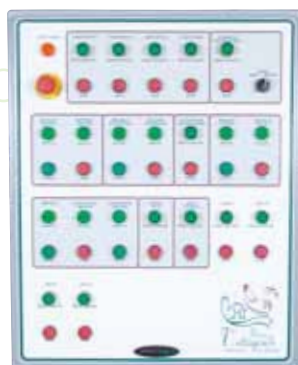

A design and manufacturing for single system

Several processes to be automated are unique, as well as the panels that they represent. Here at Multico, we are able to manufacture the perfect panel for your needs and your equipment. We can even personalize the front of your panel by graphically illustrating, in color, the controlling process in order to facilitate for you the visualization of the panel's operations.

Design and manufacturing of mass production

We service, among our established clients, several original equipment manufacturers (OEM) whose needs often include several examples of a very specific type of panel, able to control the equipment that they manufacture.

We are perfectly equipped to reply to these types of requests and to insure that each copy be identical to the original plans.



Programming of programmable logic controller (PLC)

The applications and processes, often very complex, met within the industrial field require sometimes the use of components such as PLC, human machine interface (HMI) as well as motor variable speed controller.

The programming of these devices is another service that we offer to our clients and we assure the final testing in order to validate that our systems operate as well under real conditions as they do in the factory.



Panels for wastewater pumping

Among the many industrial applications realized over the years, we must mention the sector of wastewater pumping. The experience acquired allowed us recently to introduce a new generation of control panels for pumping with still more flexibility and more options of all kinds in order to answer the ever-growing needs in this field of activity.

