

Model IRP



- Prevents spillage
- Operates irrespectively of product composition and humidity
- Several mounting possibilities
- No adapters required
- No adjustment required
- Long life
- Economical





Rotary blade level control for bulk materials

Model IRP

Application

For the level control of powdery products, granules and products in bulk with a maximum particle size of 15 mm. The maximum height of the product above the blade is 5 meters with densities that do not exceed 600 Kg/cu.m.

For heights and densities above these figures, consult the manufacturer.

Location

The controller should be placed in an adequate location so that the incoming product reaches the blade when filling the container and frees it when being emptied. THE PRODUCT SHOULD NEVER FALL DIRECTLY ONTO THE BLADE. If necessary a protective roof should be used.

Sensitivity

These controllers are supplied already pre-set by the factory and no further adjustment is necessary.

Operation

The operation of the controllers is centred on a low speed, synchronous motor-gear unit. A blade, which is located on the product side, is driven by the motor-gear unit by means of a double bearing shaft. When the product reaches the blade and it finds resistance to movement, the gear-motor rotates on its own shaft and activates two micro switches. One disconnects the motor and the other acts on the control mechanisms. When the blade is free of product, the motor-gear unit, by means of a spring, reconnects and the control signal is reversed.

Technical Characteristics

Housing and Cover	Reinforced ABS Gas thread 1 1/4" for flange, sleeve or nut
Maximum operating temperature	-20 °C to +60 °C
Acceptable pressure	-0.05 +0.5 bar. Up to 1 bar with special seal
Blade	Oblique, stainless steel
Motor-gear unit	3.0 VA - 230 V - 50 Hz - 5 rpm 3.0 VA - 115 V - 50 Hz - 5 rpm 3.0 VA - 48 V - 50 Hz - 5 rpm 3.0 VA - 24 V - 50 Hz - 5 rpm 3.0 W - 24 V d.c. - 5 rpm (With ac motor. Conversion from d.c. to a.c. through a converter incorporated in the controller)
Micro switch	Single pole inverter, 10A - 250 V a. c. Voltage free
Disconnection delay	Around 2 seconds
Cable inlet	2 threaded holes M-20
Weight	Around 800 grams
Protection	IP-65

We can supply on request:

- Flange, A 25-110.
- Nut, 1 1/4" G.
- Welding Sleeve 1 1/4".
- 8 mm thick foamed rubber gaskets, suitable for mounting on flat and round surfaces.

Rotary blade level control for bulk materials

Model IRP

Connections

The electrical connections should be carried out according to that indicated in the diagram:

- ① Common
- ② Normally closed
- ③ Normally open
- ⑤ Earth
- ⑦ Line to motor
- ⑧ Line to motor

The terminals on the left correspond to the control micro switch and with the blade in motion.

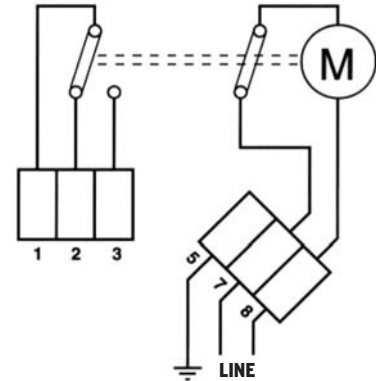

Check if the connection voltage corresponds to that indicated on the nameplate of the circuit

Voltage should be permanently applied to the motor during the working process. The motor disconnects automatically when the movement of the blades is impaired.

Automatic level control for loading a silo

This diagram is the typical one for an automatic control which responds to the fluctuating levels of the material in the silo.

When the material leaves the blade free at the lower level, the filling mechanism starts up, and stops when the material reaches the blade at the upper level.

The cycle re-starts when the lower level blade is left free.

VOLTAGE SHOULD BE PERMANENTLY APPLIED TO THE MOTOR OF EACH CONTROLLER DURING THE WORKING PROCESS.

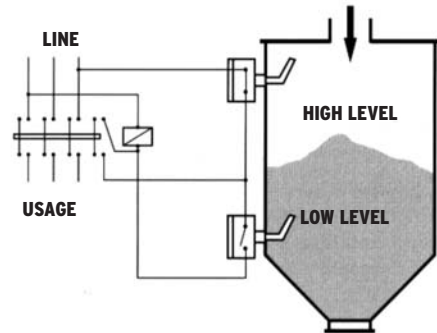

Dimensions

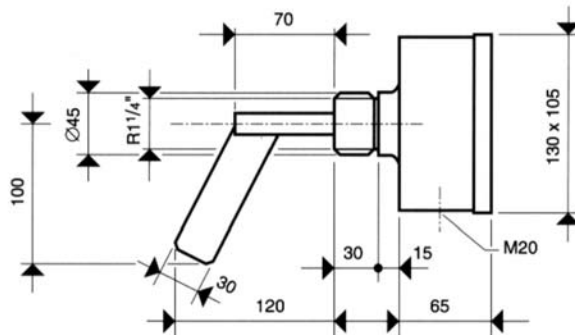

Mounting Flange

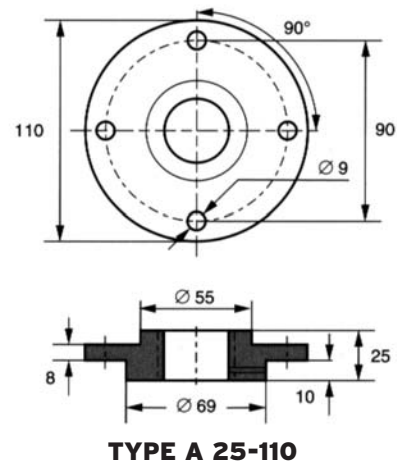



Rotary blade level control for bulk materials

Model IRP

Mounting suggestions

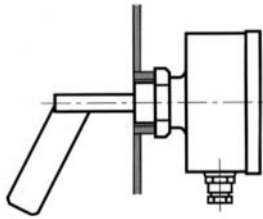

Fastening by sleeve and nut

Drill a 43 mm hole in the plate and weld a 20 mm long sleeve with an internal gas thread of 1 1/4". Introduce the blade, place the controller in the desired position and fasten it with a nut.

Protective roof-plate

When the flow of the incoming material hits the blades, it is advisable to protect them with a roof-plate. These plates are also advisable at the low and intermediate levels, when the material with densities up to 600 Kg/cu.m. reaches a height of 5 meters above them. This height should be proportionally reduced when the density of the material to be controlled increases.

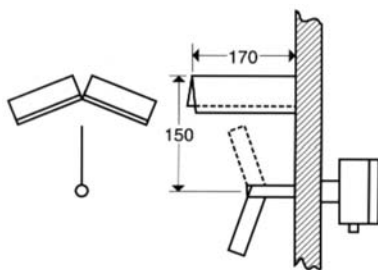

Fastening by two nuts

Drill a 43 mm hole. Introduce the blade and fasten the controller with the nuts.

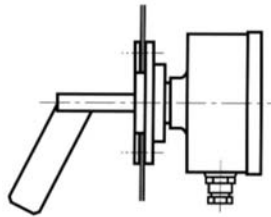

Fastening to fabric silos with two flanges

Drill four holes in a counterflange which coincide with the flange of the controller and thread them to M8. Make the appropriate holes in the silo fabric and fasten the controller with four screws.

When mounted at the top it is not advisable to use extensions longer than 400 mm.

Fastening by flange

After drilling a 70 mm hole, proceed as detailed below:

- With four M8 screws when the plate is thick enough.
- With four M8 bolts.
- By welding four M8 threaded studs to the plate.
- By welding a plate or flange, drilling and threading four M8 holes.

